

# HZ SERIES

## HZ160RT/HZ160JRT

### SELF-PROPELLED ARTICULATED BOOMS



#### Standard Features

- Self-leveling platform
- Hydraulic rotation platform
- Hall effect fully proportional controls
- Driving confirm
- AC wiring to platform
- Horn
- Hour meter
- Tilt alarm
- Positive traction drive
- Dual speed motor
- Emergency pump
- CAN intelligent control
- Overload limited

#### Options Features

- 2.4m platform
- Swing axis
- Platform swing gate
- Platform alternate leverage
- Welder connecting packages
- Welder wire connecting to the platform
- Air line to the platform
- Hydraulic oil cooler
- Hostile environment packages
- Anti-crash air packages
- Tool tray
- Alarm packages
- Platform work lights

Model	HZ160 RT/HZ160J RT
Lift capacity max	230kg
Working height max	16.00m
Working platform height max	14.00m
Working platform outreach max	7.70m
Across height max	7.40m
Turntable rotation	360 discrete
Drive speed, stowed	4.9km/h (7.0km/h 4wd)
Drive speed, extended	1.0km/h
Platform rotation	180°
Boom swing	0/140°
Platform size A*B*H	1.8m x 0.76m x 1.1m
Leveling platform	Hydraulic level
Drive wheels number	2 (4 /4WD)
Steering wheel number	2
Drive	Diesel motor
System voltage	DC12V
Tire size	33"12-20
Controls	Electrical proportional control
Turning radius-(outside)	4.00m
Turning radius-(inside)	1.70m
Turntable tailswing	0
Maximum lateral force	400N
Tilt angle max	3°
Wind speed allowed max	12.5m/s
Gradeability	30% (45%4WD)
Height-stowed C	2.30m
Length-stowed D	6.0m/6.50m
Width-stowed E	2.00m
Wheelbase F	2.00m
Ground clearance G	0.36m
Hydraulic tank capacity	110L
Feul tank capacity	65L
Total weight	6.1T/6.3T

HZ160 RT Working Range

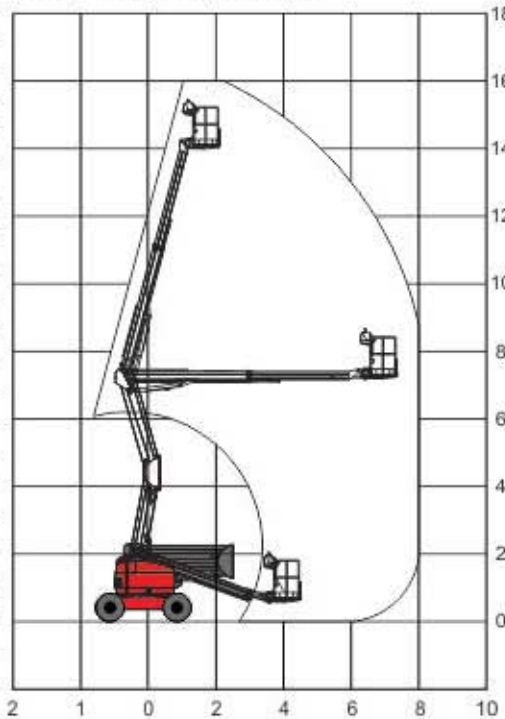

HZ160JRT Working Range

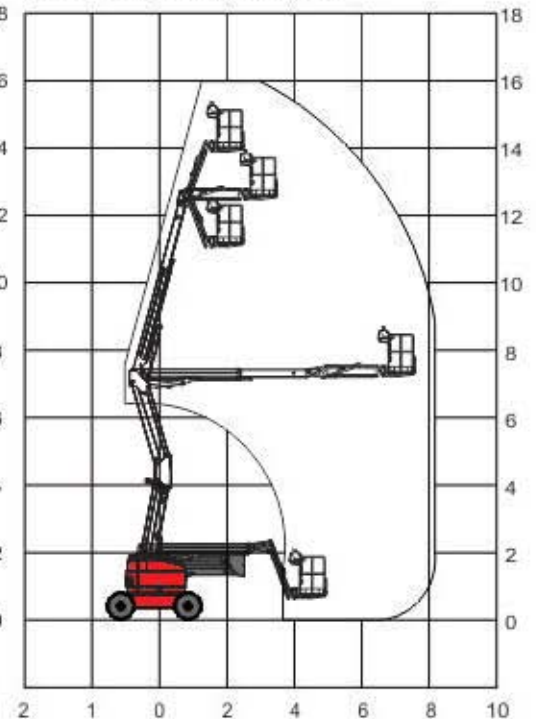

\*The metric system height is 2 meters higher than platform height, the imperial height is 6 feet than platform height

\*\*In the rising mode, the machine is designed to operate on a solid flat surface.

\*\*\*Climbing ability is suitable for driving on the slope, the slope classification reference operation manual

\*\*\*\*Weight according to the options and standards vary from country to country

HZ160 RT Collecting Chart

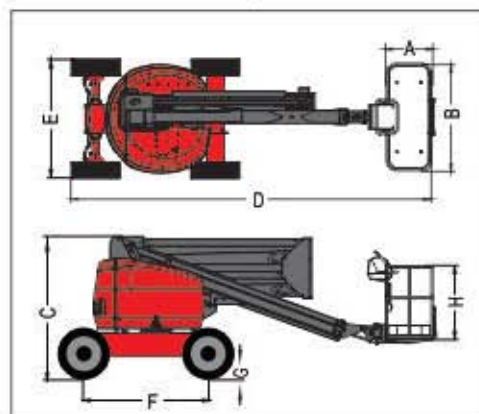

HZ160JRT Collecting Chart

